

Reality Hologram

How does an electron not fall on the nucleus?

Quantum physics postulates that the electron in the stationary state doesn't lose energy, and it rotates around the nucleus forever. Is it quite so? Without receiving some energy of any kind?

The energy is coming from the Sun (more generally any star) into quanta of energy within a particle τ neutrino that provides the continuous movement and even the existence of matter itself. It has the bigger energy between the neutrinos and generates movement, gravity, and time in the reality that we experience, and that is non-created light. The energy absorbed by an electron in the hydrogen we consider nonrelativistic Newton's law with "V" the speed of Hydrogen's electron, "ec" the charge, "c" the speed of light, "ε" the electrical

permittivity: $m \frac{v^2}{r} = \frac{1}{4\pi\epsilon} \frac{ec^2}{r^2} \Rightarrow V^2 = \frac{ec^2}{4\pi\epsilon mr}$ (The centripetal force is equal to the electrostatic force). Total energy

$$E = m \frac{v^2}{2} - \frac{1}{4\pi\epsilon} \frac{ec^2}{r} = \frac{m}{2} \frac{ec^2}{4\pi\epsilon mr} - \frac{1}{4\pi\epsilon} \frac{ec^2}{r} = \frac{1}{8\pi\epsilon} \frac{ec^2}{r}$$

Power radiated, with Larmor's formula. $\frac{dE}{dt} = -\frac{ec^2 a^2}{6\pi\epsilon c^3} = -\frac{ec^2}{6\pi\epsilon c^3} \left(\frac{v^2}{r}\right)^2 = -\frac{ec^6}{96(\pi\epsilon c)^3 m^2 r^4}$ Where "a" is centripetal acceleration, $1 = -\frac{96(\pi\epsilon c)^3 m^2 r^4}{ec^6} \frac{dE}{dt} =$

$$-\frac{96(\pi\epsilon c)^3 m^2 r^4}{ec^6} \frac{d}{dt} \left(-\frac{1}{8\pi\epsilon} \frac{ec^2}{r}\right) = -3c^3 \left(\frac{4\pi\epsilon m r}{ec^2}\right)^2 \frac{dr}{dt}$$
 and integrating

$$T_0 = \int_0^{t_0} dt = -3c^3 \left(\frac{4\pi\epsilon m}{ec^2}\right)^2 \int_{r_0}^0 r^2 \frac{dr}{dt} dt = -3c^3 \left(\frac{4\pi\epsilon m}{ec^2}\right)^2 \int_{r_0}^0 r^2 dr$$

$$T_0 = \left(\frac{4\pi\epsilon m}{ec^2}\right)^2 \cdot (rb \cdot c)^3$$
 as in <http://www.michaelvio.byethost8.com/Tint.pdf>

Thus, the Hydrogen's electron must receive energy every $T_0 = 6.22 \cdot 10^{-11}$ sec, so the Hydrogen's electron won't fall on the nucleus. There are 20 quanta of (tau) τ neutrinos' energy that fully charge a Hydrogen's electron with energy in ~ 1 ns when the hole τ 's kinetic energy, about 0.924eV, is transferred to the electron. Hydrogen's electron won't fall on the nucleus. *Every $6,22 \cdot 10^{-11}$ sec, the electron charge is changing, forming a dipole and rearranging charge in the atom, thus forming a pair of π^+ and π^- exchanging charge between the electron and the proton.*

But probably the reaction $e + \hat{\tau} \xrightarrow{trans} e + \hat{\tau} + \pi^+ + \pi^- + \hat{\mu} + \Delta E$ (1) is more complex in the equation

supplying energy to the graviton $e + \hat{\nu} \xrightarrow{trans} e + \Delta E_1$ (2) With a rest mass of 0.00038eV/c² & Kinetic energy of about 0.0018eV, bringing a plus of 0.2 % the number of collisions is ~ 20 times greater than with τ neutrino, thus the energy intake is $\sim 3 \div 5\%$. In the nucleus, we have a τ neutrino that will collide with a pair of a proton and neutron, generating the process of continuous migration of protons, generating gravity, and the μ neutrino that generates the hologram of space <http://www.michaelvio.byethost8.com/ElecFall.pdf>:

$$p + \hat{\nu} \xrightarrow{transf} n + \hat{posit} \xrightarrow{decay} (p + e + \hat{\nu}) + \hat{posit} = p + (e + \hat{posit}) = p$$
 and equation:

$$p + \hat{\tau} \xrightarrow{transf} n + \hat{\nu} + \pi^+ + \hat{\mu} \xrightarrow{decay} (p + e + \hat{\nu}) + \hat{\mu} + \hat{\pi}^- + \pi^+ = p + (e + \pi^+) = p + \mu + \Delta E_2$$

I guess that they receive quanta of energy for every predetermined period of around $\sim 6 \cdot 10^{-11}$ sec for a Hydrogen atom at room temperature, 1-S orbital, there is a reaction in an electron collides with a τ neutrino as in the equation below where monopole is meson, the lightest pion π^+ , π^- with a lower rest mass of 0.007eV/c². And the τ neutrino will collide with a pair of protons and neutrons, generating the process of continuous migration of protons, generating gravity, and the μ neutrino that generates the hologram of space:

$$p + \hat{\tau} \xrightarrow{transf} n + \hat{\nu} + \pi^+ + \hat{\mu} \xrightarrow{decay} (p + e + \hat{\nu}) + \hat{\mu} + \hat{\pi}^- + \pi^+ = p + (e + \pi^+) + \Delta E \quad (2)$$

in the Hydrogen nucleus. All the fundamental particles: proton, electron, neutron, photon, magnetron, TermalParticle, and phonon interact with τ neutrino and receive a constant amount of energy and temporal ionization. The rest mass of the τ neutrino, produced only in stars, like the Sun, or any star that glows, is around ~ 0.188 eV/c² and that amount is transferred to elementary particles every millionth of a second (microsecond). Thus, we may estimate with Einstein's equation for τ neutrino of energy ~ 0.925 eV with rest

$$\text{mass } 0.188\text{eV}/c^2 \text{ so: } E_\tau = \frac{m \cdot c^2}{\sqrt{1 - \frac{v^2}{c^2}}} = \frac{0.188\text{eV}}{\sqrt{1 - \frac{v^2}{c^2}}} = 0.925\text{eV}; V = 0.97913 \cdot c, \text{ thus } 97.9128\% \text{ of the light speed and}$$

wavelength $\sim 1.34\mu\text{m}$.

In the case of the double-slit experiment in which an electron beam creates the diffraction pattern on the screen, the application of a wavelength beam of light over 1.34μm wavelength, with the energy apport of a τ neutrino, for photons with less than 0.9403eV energy, diffraction appears. When observing with photons of optical window (400-700nm) of the slit that passes the electron doesn't interfere because of blocking the temporal ionization of the electron. Below the τ neutrino kinetic energy $E_{\tau} \sim 0.925\text{eV}$, photons with a wavelength of 1317nm, the diffraction will appear. The ratio between the perturbing energy of the photon and the energy of the particle τ neutrino E_{τ} coming from the Sun is as in the equation: $f + \left[\tau \xrightarrow{\text{interaction}} f + \mu \right]$. Thus, in the energy balance equation, we approximate the speed “~c” for all particles:

$$E = 0.188 + 0.925 - (0.0087 + 0.02) \cdot 12 + 0.20 = 0.925(\text{eV}); \text{ \þthreshold value } 0.925\text{eV} \text{ and } \sim 1.34\text{nm}.$$

The twelve μ neutrino with a rest mass of 0.0087eV/c² and a kinetic energy of ~0.020eV. In the double-slit experiment in which an electron beam creates the diffraction pattern on the screen when a photon beam appears, to see what slit the electron passes the diffraction disappears and a reaction occurs between the incident "f" photon of energy $h\nu$ and electron, that blocks the passage of the electron from the wave to the particle during a number N of time quanta T_{qelec} . Thus, observing with a laser beam with a wavelength lower than 1.34μm will no longer completely block the process of transitioning the particle into a probability wave, so that the interference will no longer appear in the process. This can be verified experimentally with a CO₂ laser of 10.6 microns; varying the wavelength, you can see the exact value.

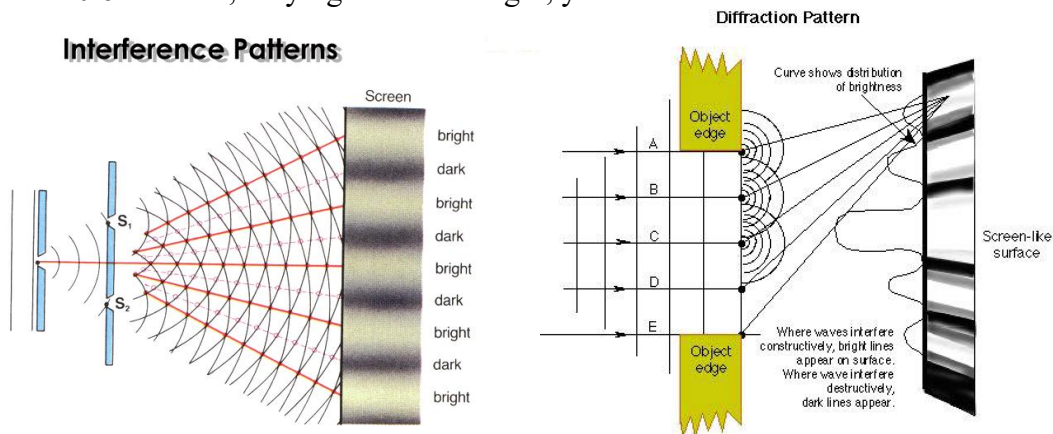

For photons with an energy of approximately 0.925eV (the photons with wavelength over 1.34μm), diffraction appears. The interference does not appear when observing the photon within the optical window, due to the interaction of photons and τ Tau neutrino arriving from the Sun, generating μ muon at the collisions with microparticles.

For the energy of photons lower than 0.925eV, the diffraction appears, but the threshold value is almost the same wavelength => 1.34μm for electrons. That's a strange behavior of matter, thus from another point of view it's the consequence of the granularity of space-time & mass and the mechanism explained above. The grid of τ neutrinos that are coming from is similar to the Cosmic Microwave Background because tau neutrinos are coming from all the stars, and we presume that there is a similarity between CMB and the τ neutrino grid.

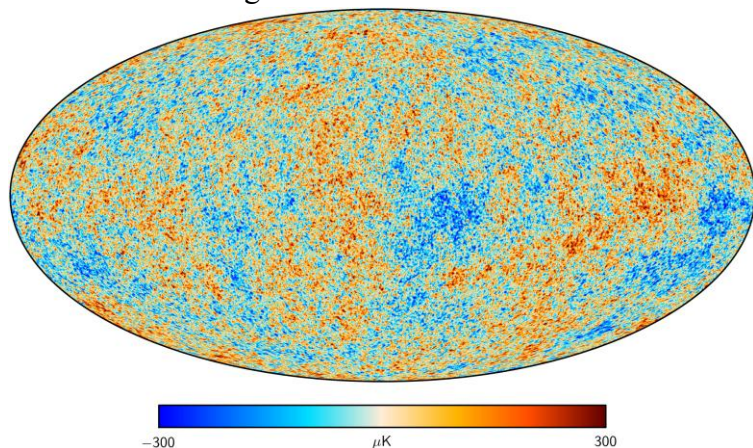

The temperature fluctuation is less than $\sim 10^{-3}$; thus, the variation of τ neutrino flux is similarly probably less than 0.3-0.4%, in any direction.

The kinetic energy of the Tau neutrino (τ) from the Sun is around $\sim 0.925\text{eV}$, and mass $\sim 0.188\text{eV}/c^2$, and we suppose that all the stars that glow emit τ with about the same energy in the range of $\pm 0.3-0.4\%$ in any direction. For the experiment, we need a 1-micron step of the diffraction grating and a laser of wavelength 670nm, a pointer of 3-5mW, a control laser beam of 532nm, a pointer of 5mW, and eventually a laser beam of 440nm.

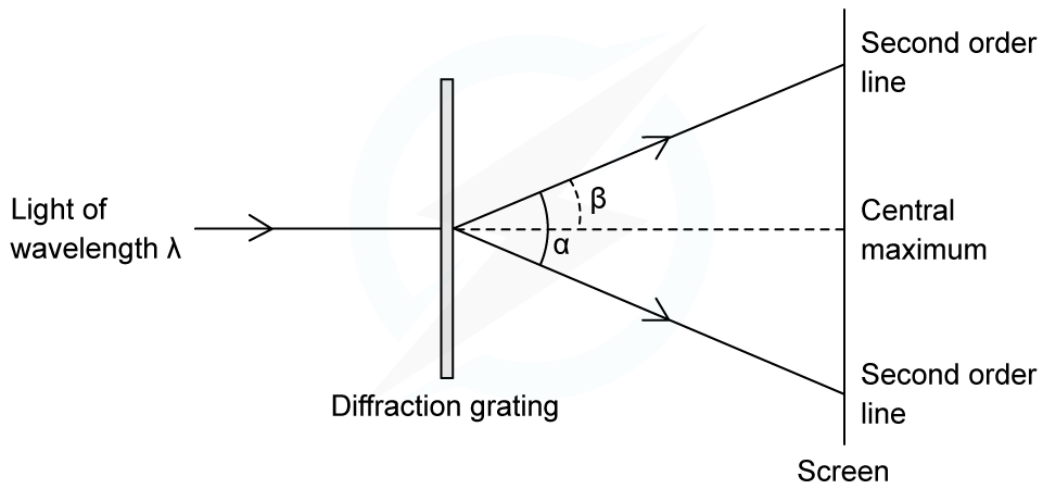

Thus, for the particular wavelength that produces the resonance between 1 photon and 1 τ neutrino, the optical interference doesn't appear. The interaction of 2 photons and a τ neutrino involves the wave function of the tau neutrino, and this phenomenon appears at 670.2nm (two-photon absorption thus the energy. $E_\tau = h \cdot c / (2 \cdot 10^{-9} \cdot 670.2) \text{ (nm)}$ $E_\tau = 0.925\text{eV}$, so at resonance, the μ neutrinos are less generated. It's a lucky coincidence because the wavelength shouldn't vary by more than one nm, so the phenomenon appears, and on my red pointer write the wavelength 630-680nm and output 3-5mW. The 1000 lines/millimeters that I bought from Astromagazin <https://astromagazin.ro/accesorii-spectroscopie/3113-reea-de-difracie-1000liniimm.html>

Thus, the pointer of 532nm is a usual one from the market, with the power of 5mW, and you have the picture below. The equation of a transparent grating is $d \cdot \sin(\theta_i) - d \cdot \sin(\theta_m) = m \cdot \lambda$ (1)

When the planar light wave is normal to the diffraction light has maxima at diffraction angles θ_m given by the diffraction equation as $d \cdot \sin(\theta_m) = m \cdot \lambda$ (2)

The grating equation is: $N \cdot \lambda = \sin(\theta)$ where N equals 1000 lines/mm, thus for $\lambda=0.000532\text{mm}$ we have $\theta = 32.14$ degrees, and for 660nm we have $\theta = 41.22$ degrees.

Thus, for $m = 2$, the second-order is over 90 degrees, and it doesn't exist ($\sin(\theta) > 1$ absurd).

We estimate from the picture of interference that the angular distance between the three maxima is about ~ 0.135 radians due to the oscillation of μ neutrino interacting with photons. From equation (2), we have (3):

$$\theta_m = \arcsin \frac{m \cdot \lambda}{d}$$

And $\theta_{m1} = 0.135$ degrees, thus \sim around 8 minutes of arc (4) $\frac{180 \arcsin(0.532)}{\pi} - \frac{180 \arcsin(0.534)}{\pi} = -0.135$

Respectively, for $\theta_{m2} = 0.135$ degrees, we have (5) $\frac{180 \arcsin(0.536)}{\pi} - \frac{180 \arcsin(0.534)}{\pi} = 0.135$

Thus, the decrease in wavelength is less than 2 nm due to the oscillation, the energy formula in eV is (6):

$$E_\mu = \frac{1239}{532} - \frac{1239}{534} = 0.0087\text{eV} \text{ for } \Delta \text{ wavelength } \sim 2\text{nm} (\sim 20 \text{ Angstrom})$$

The muon neutrino mass, according to the oscillation observed and measured in other experiments, is around $\sim 0.0088\text{eV}/c^2$ but the energy associated with the momentum of the muon neutrino is the same as the value in eV, and this is the energy of several muon neutrinos that are generated at the incidence between a photon and a τ neutrino. $f + \tau \xrightarrow{\text{interaction}} f + \mu$

This is the qualitative phenomenon; the other approach is in the intensity of the 3 dots on the wall, but I haven't finished yet.

$$E_\mu = \frac{m \cdot c^2}{\sqrt{1 - \frac{v^2}{c^2}}} = \frac{0.087\text{eV}}{\sqrt{1 - \frac{v^2}{c^2}}} = 0.02\text{eV} \text{ so } v_\mu = 0.9004304526 \cdot c, \text{ thus } 97.34\% \text{ of the light speed and kinetic energy}$$

$$E_\mu = 0.020\text{eV} \pm 10\%$$

https://www.researchgate.net/publication/339913143_DIFFRACTION_GRATING_HANDBOOK_eighth_edition

For the wavelength 532nm, the beam passing through the 1-micron grating produces 3 maximum points, as in the picture:

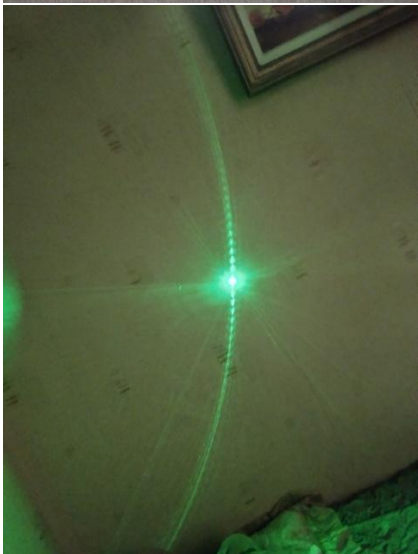

The wavelength 670.2nm, the beam passing through the 1-micron grating, didn't produce maximum points as in the picture below:



With a wavelength of 670.2nm, the beam passing through the 1-micron grating didn't produce maximum points as in the picture above.

The lower images, green and red, are made with the interference produced by laser & human hair.

https://www.youtube.com/watch?v=v_uBaBuarEM&ab_channel=LookingGlassUniverse

Is reality a Hologram? No, the reality is material, but as you can see, almost all microparticles (except probably the particle with quark $t = -1$, γ , and Activate particles) that collide with τ neutrino engulf energy ΔE and emit μ neutrinos, thus related to the Higgs Boson and mass quanta. The multitude of μ particles can create a hologram of reality because there is a one-to-one correspondence between all constituent particles of matter reality and the place where the μ muon neutrino has no space to expand. That place is the closure of the local Universe, or more generally, the closure of the space region if there is a degeneration of space around where there is any kind of degeneration of space.

<http://www.michaelvio.byethost8.com/grating.pdf>

In conclusion, when a particle passes through a grid, the number of quanta N that stop the wave-particle transitions is: $N = (h\nu - E_\tau) / E_\mu$, where thus the ratio of the incident photon minus the energy of tau neutrino τ (0.925eV) and the energy of muon neutrino μ . The condition is that the incident photon energy should exceed the value of tau τ neutrino energy by at least the muon energy.

8 Nov. 2025